

## Description

This machine is a kind of piston and ball controlling pump, and the conveying line, piston and cylinder is specially designed and processed, so this machine is workable for high pressure grouting/spraying mortar (the mixture of sand:cement:water). And is successfully used in sealing, strengthening, stabilizing of rock and soil, tunneling, building hydro-power project, etc, and also used for spraying mortar in construction and 3D Panel, etc.

The RG50/40 is available in the following versions.

- BASIC                      Electric drive
- DIESEL                     Diesel drive

## Technical Data

Working Pressure	:	4 MPa / 580psi
Conveying distance		horizontal 120m; vertical 50m
Hopper capacity		160L
Frequency of piston	:	95 / min
Working Cylinder ID		φ 90 mm
Piston Stroke		85 mm
Outlet Hose ID		φ 50 mm
Inlet Hose ID		φ 75 mm
Overall dimension (LxWxH)		1610x1024x900mm
Weight	:	300 kg

## Drive

### Electric (BASIC)

Motor output	:	5.5 kW/7.5hp
Speed range	:	1450 rpm
Voltages	:	380 V 50 Hz
		440 V 50/60 Hz
		220 V 50/60 Hz

### Diesel (DIESEL)

Motor output	:	7 kW/10hp
Speed range	:	2200 rpm

The information contained in this document is believed to correct but RISEN accepts no liability for any errors it contains, and reserves the right to alter specifications without notice. Please consult the respective machine manual for all matters related to operations and maintenance.

**Theoretical conveying date**

Hose Φ (mm)	Conveying output <sup>1)</sup> (L/min)	Max. grain (mm)	Max. aggregate ratio (cement/sand)
50	50	6	1/3

1) If motor with 60 Hz =20% higher conveying capacity

**Working Principle**

The mixed materials complying with the required ratio are filled into hopper, piston reciprocate driven by reducer and the connecting rod, and with this action, the mortar in the hopper is sucked in the cylinder through the sucking entrance, and is discharged through the discharging exit.

- Return Valve — Open it and make the materials return to the hopper when the block happens momentarily.

- Agitator Paddle—It reciprocate in the horizontal direction driven by reducer and the connecting rod, and agitate the material to prevent eduction and deposition happening.

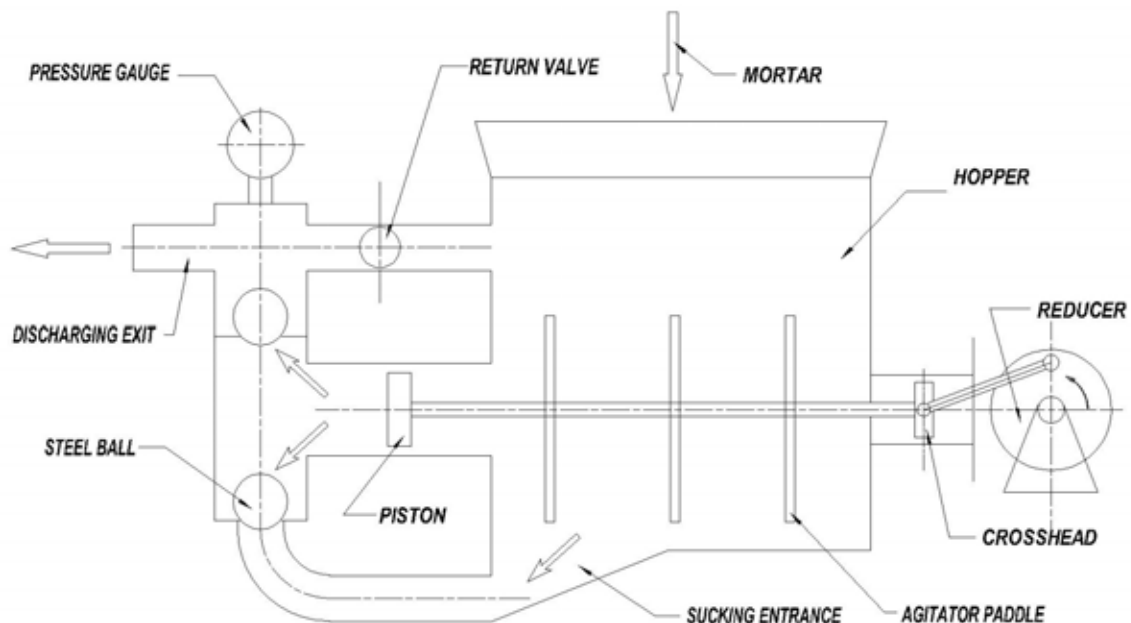

The information contained in this document is believed to correct but RISEN accepts no liability for any errors it contains, and reserves the right to alter specifications without notice. Please consult the respective machine manual for all matters related to operations and maintenance.

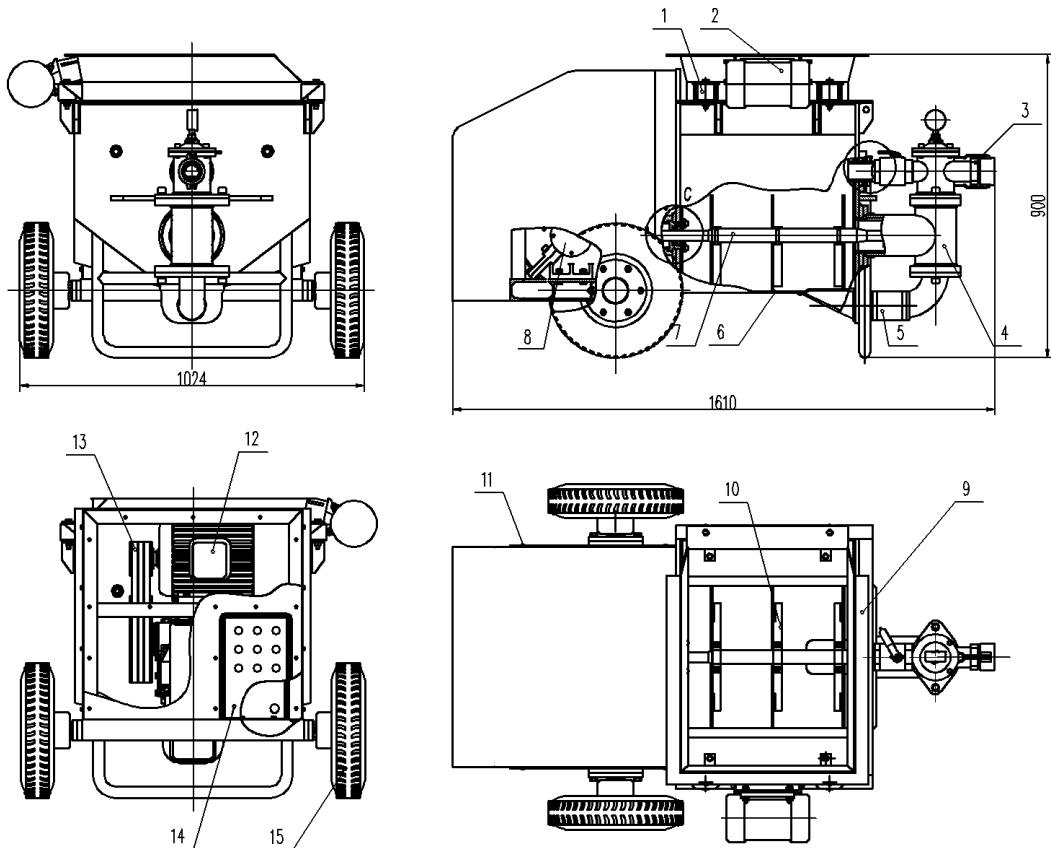

- |                    |                         |                             |
|--------------------|-------------------------|-----------------------------|
| 1.Vibrating Spring | 2.Vibrating Motor       | 3.Quick joint               |
| 4.Pump Head        | 5.Sucking Hose          | 6.Hopper                    |
| 7.Piston Rod       | 8.Reducer               | 9.Vibrating Hopper          |
| 10.Agitator Paddle | 11.Cover                | 12.Electric Motor or diesel |
| 13. V Belt         | 14.Electric Control Box | 15.Soild Tyre               |

<b>Spraying</b>	<b>Mortar</b>	<b>Description</b>
-----------------	---------------	--------------------

**A. Request Compressure Air**

The request compressure air should be 4-7bar(87-100psi), and the output is 0.3m<sup>3</sup>/min(11CFM). When spraying, the operator should adjust air pressure

The information contained in this document is believed to correct but RISEN accepts no liability for any errors it contains, and reserves the right to alter specifications without notice. Please consult the respective machine manual for all matters related to operations and maintenance.

and output in order to make the spraying layer uniformity and reducing rebound.

### B. Spraying Description

- 1, Spraying Thickness every time: the recommending spraying thickness every time is 3 to 5 mm.
- 2, Spraying distance: The recommending spraying distance is 350mm.
- 3, Spraying angle: The recommending spraying angle is that nozzle is vertical to the wall surface.
- 4, Spraying route: The recommending spraying route is from lower to upper with “s” shape.

### C. Mortar Ratio

The workable mortar should select middle sand, which the quantity of 1mm sand by weight is 60 percent of the total sand. And max. sand grain is less than 5mm with fineness modulus  $>2.3$ . For the workable mortar, please refer to the following table:

Ratio	1: 2.5 (volume) 或 1: 3.24: 0.97 (weight)	
Name	Volume m3	Weight (T)
Cement	0.3664	0.4376
Dry Sand	0.916	1.4198
Water	0.347	0.347

The information contained in this document is believed to correct but RISEN accepts no liability for any errors it contains, and reserves the right to alter specifications without notice. Please consult the respective machine manual for all matters related to operations and maintenance.

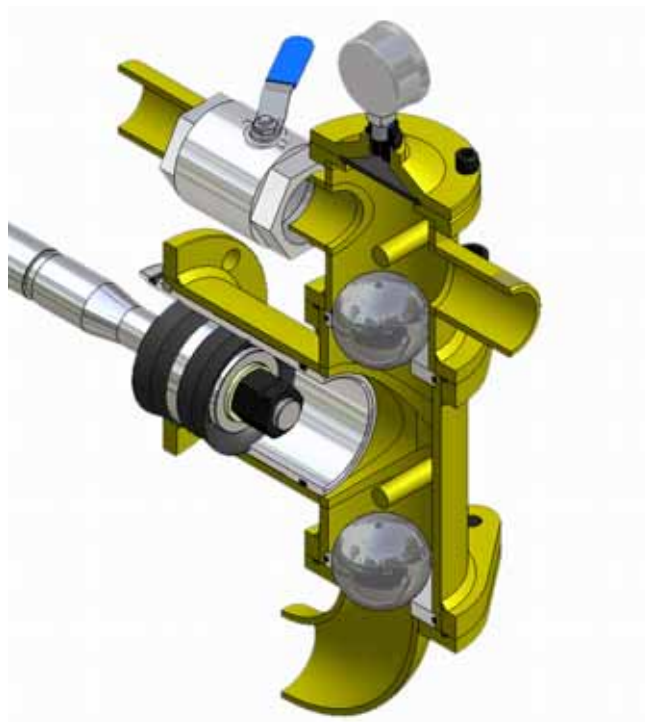
**RG50/40****Pump Head Assemble**

The information contained in this document is believed to be correct but RISEN accepts no liability for any errors it contains, and reserves the right to alter specifications without notice. Please consult the respective machine manual for all matters related to operations and maintenance.